

Keysight HMMC-2027

DC–26.5 GHz SPDT

GaAs MMIC Switch

1GG7-8005

Data Sheet

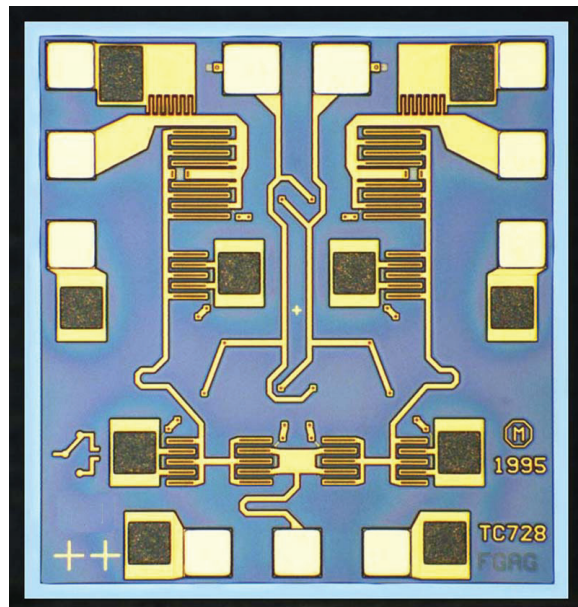

Features

- Outputs terminated in 50 Ω when off
- Frequency range: DC to 26.5 GHz
- Insertion loss: 2.5 dB @ 26.5 GHz
- Isolation: > 70 dB @ 45 MHz
30 dB @ 26.5 GHz
- Return loss: 15 dB (both input and selected output)
12 dB unselected output
- Switching speed:
< 1 ns (10%–90% RF)
- $P_{-1\text{dB}}$: 18 dBm @ 10 MHz
27 dBm @ 2 GHz
- Harmonics (DC coupled):
< -45 dBc @ 10 MHz and 5 dBm
< -65 dBc @ 2 GHz and 5 dBm

Description

The HMMC-2027 is a GaAs monolithic microwave integrated circuit (MMIC) designed for low insertion loss and high isolation from DC to 26.5 GHz. It is intended for use as a general-purpose, single-pole, double-throw (SP-DT), absorptive switch. Two series and two shunt MESFETs per throw provide 3 dB maximum insertion loss and 30 dB minimum isolation at 26.5 GHz. HMMC-2027 chips use through-substrate vias to provide ground connections to the chip backside and minimize the number of wire bonds required.

Absolute Maximum Ratings¹

Symbol	Parameters/conditions	Minimum	Maximum	Units
V_{sel}	Select voltages 1 & 2	-10.5	+3	Volts
P_{in}	RF input power		25	dBm
T_{op}	Operating temperature	-55	+125	°C
T_{st}	Storage temperature	-65	+165	°C
T_{max}	Maximum assembly temperature		+200	°C
P_{unsel}^2	Power into unselected output		15	dBm

1. Operation in excess of any one of these ratings may result in permanent damage to this device.
 $T_A = 25\text{ °C}$ except for T_{op} , T_{st} , and T_{max} .
2. Operation in excess of these @ T_{op-max} may result in permanent damage.

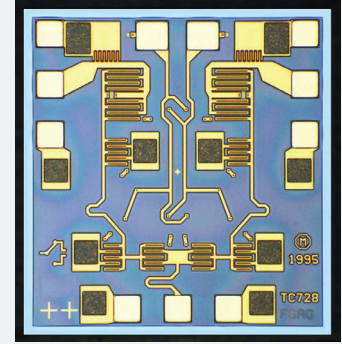

Chip size:

900 x 960 μm (35.4 x 37.8 mils)

Chip size tolerance:

$\pm 10\ \mu\text{m}$ (± 0.4 mils)

Chip thickness:

$127 \pm 15\ \mu\text{m}$ (5.0 ± 0.6 mils)

Pad dimensions:

$80 \times 80\ \mu\text{m}$ (3.2 x 3.2 mils) or larger

DC Specifications/Physical Properties

($T_A = 25\text{ }^\circ\text{C}$)

Symbol	Parameters/conditions	Minimum	Typical	Maximum	Units
I_l	Leakage current @ -10 V			200	μA
V_p	Pinch-off voltage ($V_{SEL2} = V_p$, $V_{RFout2} = +2\text{V}$, $I_{RFout2} = 2\text{ mA}$, $V_{SEL1} = -10\text{ V}$, $V_{RFout1} = \text{open}$ circuit, $V_{RFin} = \text{GND}$)	-6.75		-3.00	Volts
BV_{gss}	Breakdown voltage (Test FET w/ $V_D = V_S = \text{GND}$, $I_G = -50\text{ }\mu\text{A}$)			-13.0	Volts

RF Specifications

($T_A = 25\text{ }^\circ\text{C}$, $Z_0 = 50\text{ }\Omega$, $V_{sel-high} = 0\text{ V}$, $V_{sel-low} = -10\text{ V}$)

Symbol	Parameters/conditions	Minimum	Typical	Maximum	Units
BW	Guaranteed operating bandwidth	DC		26.5	GHz
IL	Insertion loss, RF_{in} to selected RF_{out} (ON throw), 26.5 GHz		2.5	3.0	dB
ISO	Isolation, RF_{in} to unselected RF_{out} (OFF throw), 26.5 GHz	27	30		dB
ISO	Isolation, RF_{in} to unselected RF_{out} (OFF throw), 18 GHz	40	43		dB
RL_{in}	Input return loss	12	15		dB
RL_{out-ON}	Output return loss, ON throw	13	16		dB
$RL_{out-OFF}$	Output return loss, OFF throw	9	12		dB
$P_{-1\text{ dB}}$	Input power where IL increases by 1 dB, $f_{in} = 2\text{ GHz}$		27		dBm
t_s	Switching speed, 10%-90% RF envelope, $f_{in} = 2\text{ GHz}$		1		ns

Applications

The HMMC-2027 can be used in instrumentation, communications, radar, ECM, EW, and many other systems requiring SPDT switching. It can be used for pulse modulation, port isolation, transfer switching, high-speed switching, replacement of mechanical switches, and so on.

Assembly Techniques

GaAs MMICs are ESD sensitive. ESD preventive measures must be employed in all aspects of storage, handling, and assembly.

MMIC ESD precautions, handling considerations, die attach and bonding methods are critical factors in successful GaAs MMIC performance and reliability.

Keysight Technologies, Inc. publication, *GaAs MMIC ESD, Die Attach and Bonding Guidelines*, Application Note (5991-3484EN) provides basic information on these subjects.

FET Switch Speed and Settling Time, Application Note (5991-3516EN) is also useful.

S-Parameters¹

($T_A = 25\text{ }^\circ\text{C}$, $Z_0 = 50\ \Omega$, $V_{\text{sel high}} = 0\ \text{V}$, $V_{\text{sel low}} = -10\ \text{V}$)

Frequency (GHz)	S_{11}			S_{21} (insertion loss)			S_{31} (isolation)	S_{22} (ON throw)			S_{33} (OFF throw)		
	dB	M	ang	dB	M	ang	dB	dB	M	ang	dB	M	ang
0.5	-18.28	0.12	-7.04	-1.33	0.86	-8.52	-71.40	-18.44	0.12	-9.89	-16.79	0.14	173.87
1.5	-18.53	0.12	-13.70	-1.35	0.86	-14.62	-61.02	-18.46	0.12	-19.75	-16.47	0.15	171.75
4.0	-18.92	0.11	-27.64	-1.41	0.85	-24.53	-51.67	-18.75	0.12	-38.78	-15.36	0.17	168.03
6.5	-19.43	0.11	-45.02	-1.47	0.84	-39.56	-49.50	-19.10	0.11	-63.22	-14.55	0.19	152.55
9.0	-20.57	0.09	-64.07	-1.56	0.84	-55.13	-46.87	-19.72	0.10	15.79	-14.28	0.19	136.68
11.5	-21.85	0.08	-2.59	-1.62	0.83	-71.03	-44.71	-20.91	0.09	243.63	-13.84	0.20	121.81
14.0	-23.10	0.07	258.44	-1.74	0.82	-29.63	-42.30	-22.41	0.08	217.48	-13.53	0.21	106.44
16.5	-24.05	0.06	235.82	-1.88	0.81	258.60	-41.74	-24.17	0.06	179.74	-12.95	0.23	92.94
19.0	-24.59	0.06	224.56	-1.99	0.80	242.13	-37.07	-27.09	0.04	133.20	-12.76	0.23	74.01
21.5	-25.42	0.05	206.39	-2.10	0.79	227.84	-40.39	-28.85	0.04	68.10	-13.12	0.22	68.84
24.0	-24.66	0.06	209.77	-2.10	0.78	209.72	-34.46	-24.31	0.06	6.26	-12.11	0.25	54.32
26.5	-21.90	0.08	223.86	-2.39	0.76	191.82	-31.38	-19.43	0.11	-33.31	-12.03	0.25	3

1. Three-port wafer-probed data: Port 1 = RF input, Port 2 = selected RF output (i.e., ON throw), and Port 3 = unselected RF output (i.e., OFF throw).

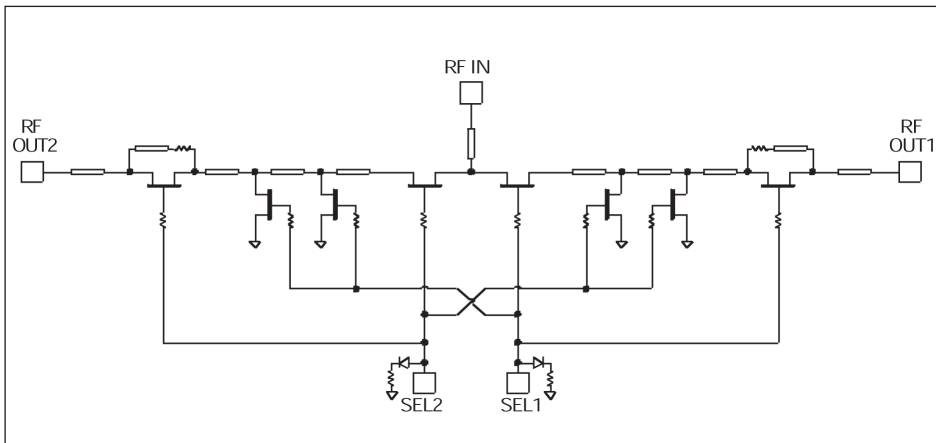

Figure 1. Schematic

Select line		RF path	
SEL1	SEL2	RF IN to RF OUT1	RF IN to RF OUT2
-10 V	0 V	Isolated	Low loss
0 V	-10 V	Low loss	Isolated

Figure 2. Recommended operating conditions
($T_A = 25\text{ }^\circ\text{C}$)

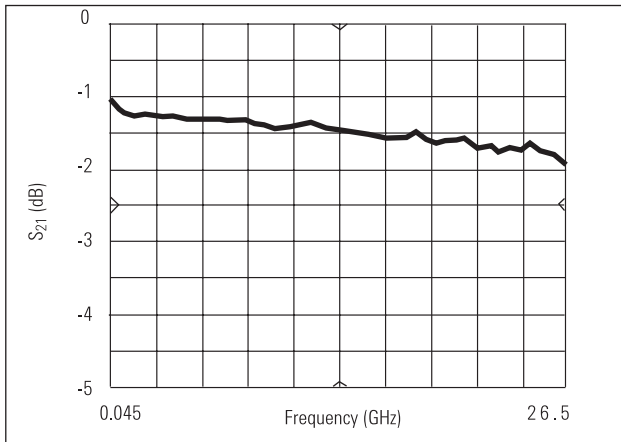

Figure 3. Insertion loss¹

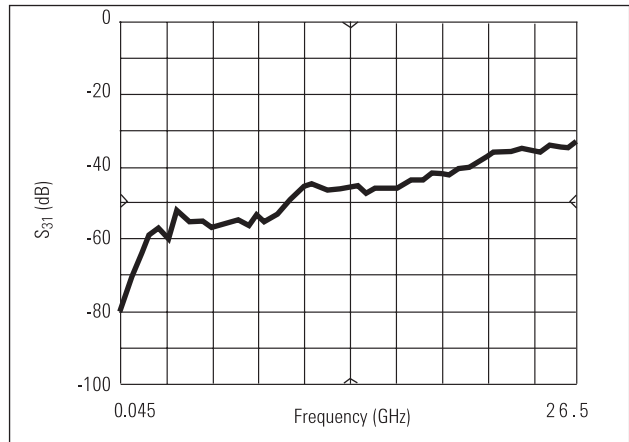

Figure 4. Input-to-output isolation¹

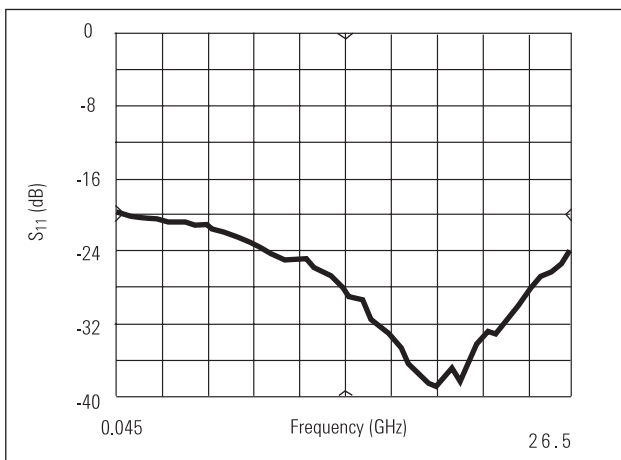

Figure 5. Input return loss¹

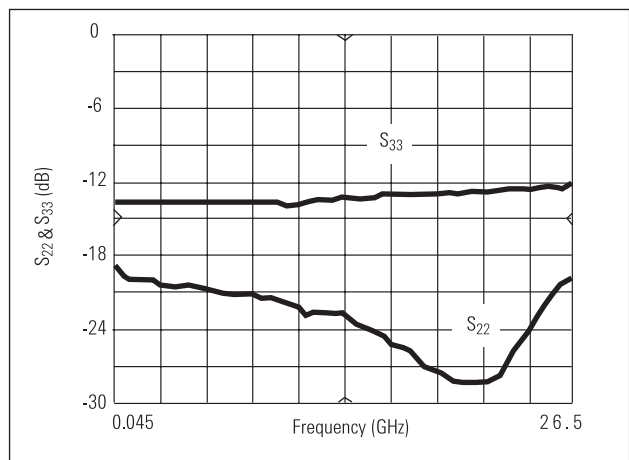

Figure 6. Output return loss¹

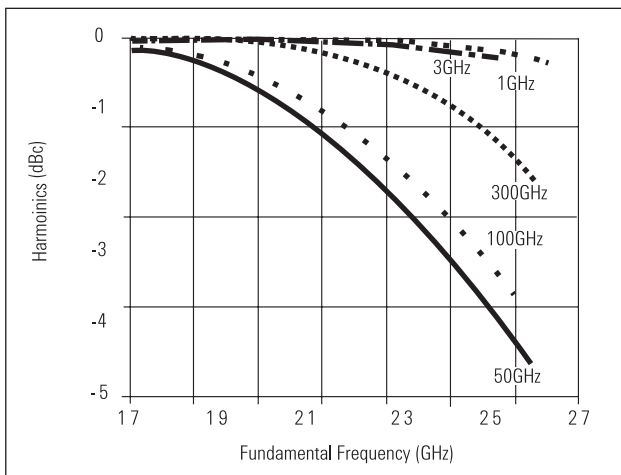

Figure 7. Gain compression²

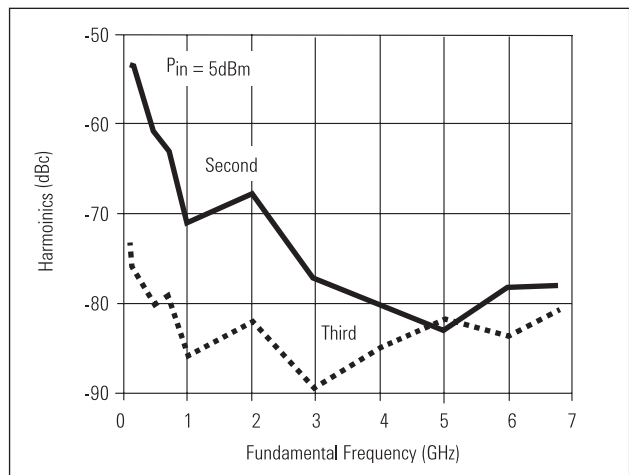

Figure 8. Harmonics^{2,3}

1. Data obtained from wafer-probed measurements.
 2. All compression and harmonic data measured on individual device mounted in a Keysight 83040 Series Modular Microcircuit Package @ $T_{case} = 25\text{ }^{\circ}\text{C}$.
 3. Harmonic data points below -80 dBc are at or near the noise floor of the measurement system.

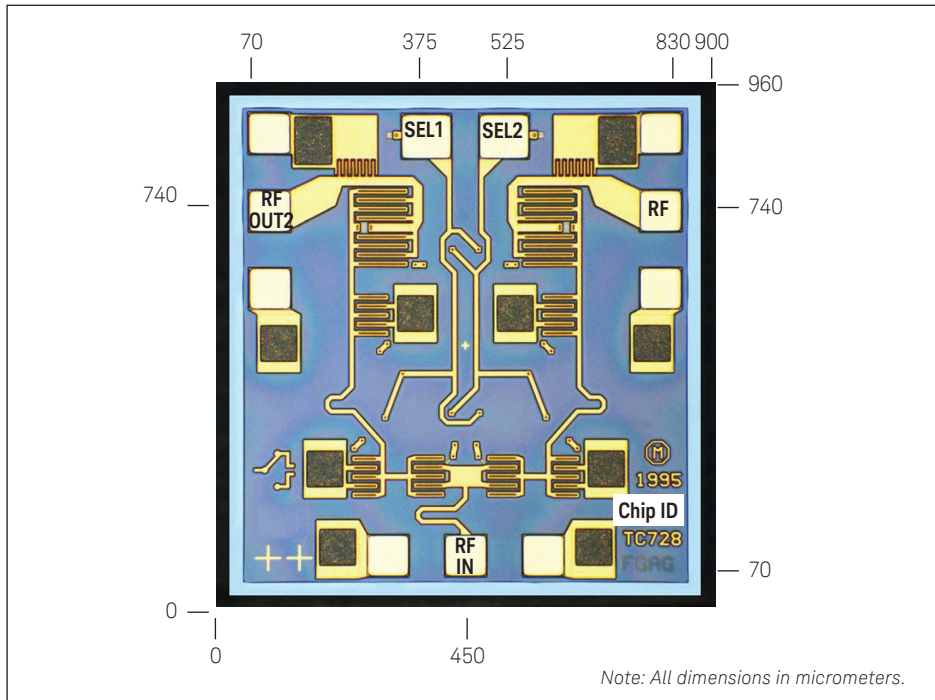

Figure 9. Bonding pad positions

This data sheet contains a variety of typical and guaranteed performance data. The information supplied should not be interpreted as a complete list of circuit specifications. Customers considering the use of this, or other Keysight GaAs ICs, for their design should obtain the current production specifications from Keysight. In this data sheet the term typical refers to the 50th percentile performance. For additional information contact Keysight MMIC_Helpline@keysight.com.



myKeysight

www.keysight.com/find/mykeysight

A personalized view into the information most relevant to you.

Three-Year Warranty

www.keysight.com/find/ThreeYearWarranty

Keysight's commitment to superior product quality and lower total cost of ownership. The only test and measurement company with three-year warranty standard on all instruments, worldwide.



Keysight Assurance Plans

www.keysight.com/find/AssurancePlans

Up to five years of protection and no budgetary surprises to ensure your instruments are operating to specification so you can rely on accurate measurements.



www.keysight.com/quality

Keysight Technologies, Inc.
DEKRA Certified ISO 9001:2008
Quality Management System



Keysight Channel Partners

www.keysight.com/find/channelpartners

Get the best of both worlds: Keysight's measurement expertise and product breadth, combined with channel partner convenience.

For more information on Keysight Technologies' products, applications or services, please contact your local Keysight office. The complete list is available at: www.keysight.com/find/contactus

Americas

Canada	(877) 894 4414
Brazil	55 11 3351 7010
Mexico	001 800 254 2440
United States	(800) 829 4444

Asia Pacific

Australia	1 800 629 485
China	800 810 0189
Hong Kong	800 938 693
India	1 800 112 929
Japan	0120 (421) 345
Korea	080 769 0800
Malaysia	1 800 888 848
Singapore	1 800 375 8100
Taiwan	0800 047 866
Other AP Countries	(65) 6375 8100

Europe & Middle East

Austria	0800 001122
Belgium	0800 58580
Finland	0800 523252
France	0805 980333
Germany	0800 6270999
Ireland	1800 832700
Israel	1 809 343051
Italy	800 599100
Luxembourg	+32 800 58580
Netherlands	0800 0233200
Russia	8800 5009286
Spain	0800 000154
Sweden	0200 882255
Switzerland	0800 805353
	Opt. 1 (DE)
	Opt. 2 (FR)
	Opt. 3 (IT)
United Kingdom	0800 0260637

For other unlisted countries:
www.keysight.com/find/contactus
(BP-07-01-14)

